



Area of Application: mechanical pressure measurement

Characteristics:

- suitable for hydraulic oil and gaseous media that do not attack any copper base alloy
- available in nominal sizes 63 and 100
- standard thread form: BSP
- housing made out of stainless steel (1.4301)
- sight glass made out of acrylic
- glycerine filled
- standard dual scales with pressure indication in bar and PSI
- U-bolt or flange mounting kit on request

Please consult our office before you use SPG with other media.

Technical Data:

System of protection: IP 65 (EN 60 529 / IEC 529)
 Accuracy class SPG-063: 1.6 ($\pm 1,6\%$ FS as per EN 837-1)
 Accuracy class SPG-100: 1.0 ($\pm 1,0\%$ FS as per EN 837-1)
 environmental temp. range: $-20^{\circ}\text{C} \dots +60^{\circ}\text{C}$
 temperature range medium: max $+60^{\circ}\text{C}$

Options (on request):

- additional scale readings including personalisation
- thread form NPT
- U-bolt and flange mounting kits are available separately as spare parts
- additional pressure ranges up to 1.000 bar max

Dimensions SPG 063

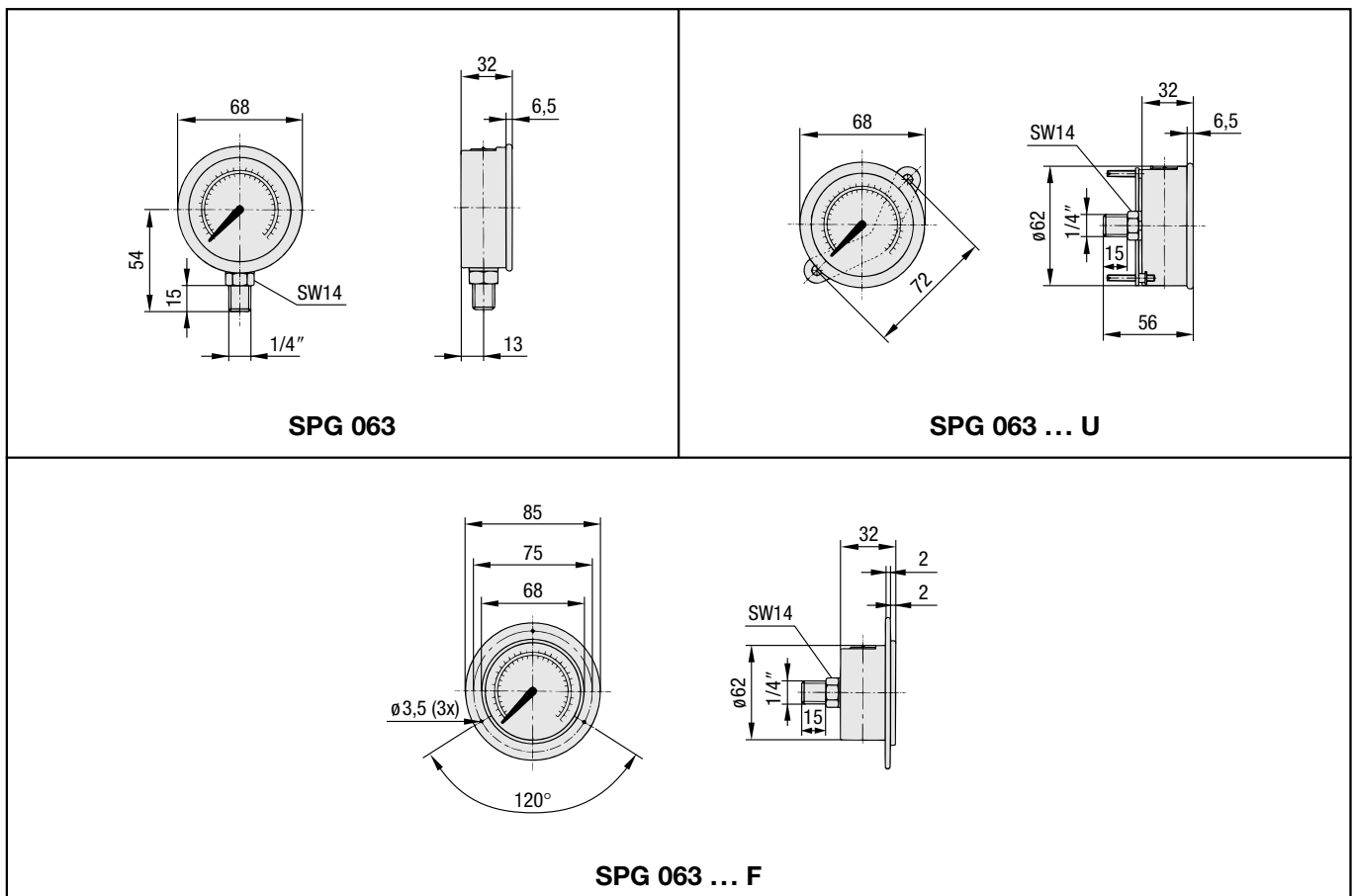

Dimensions SPG 100

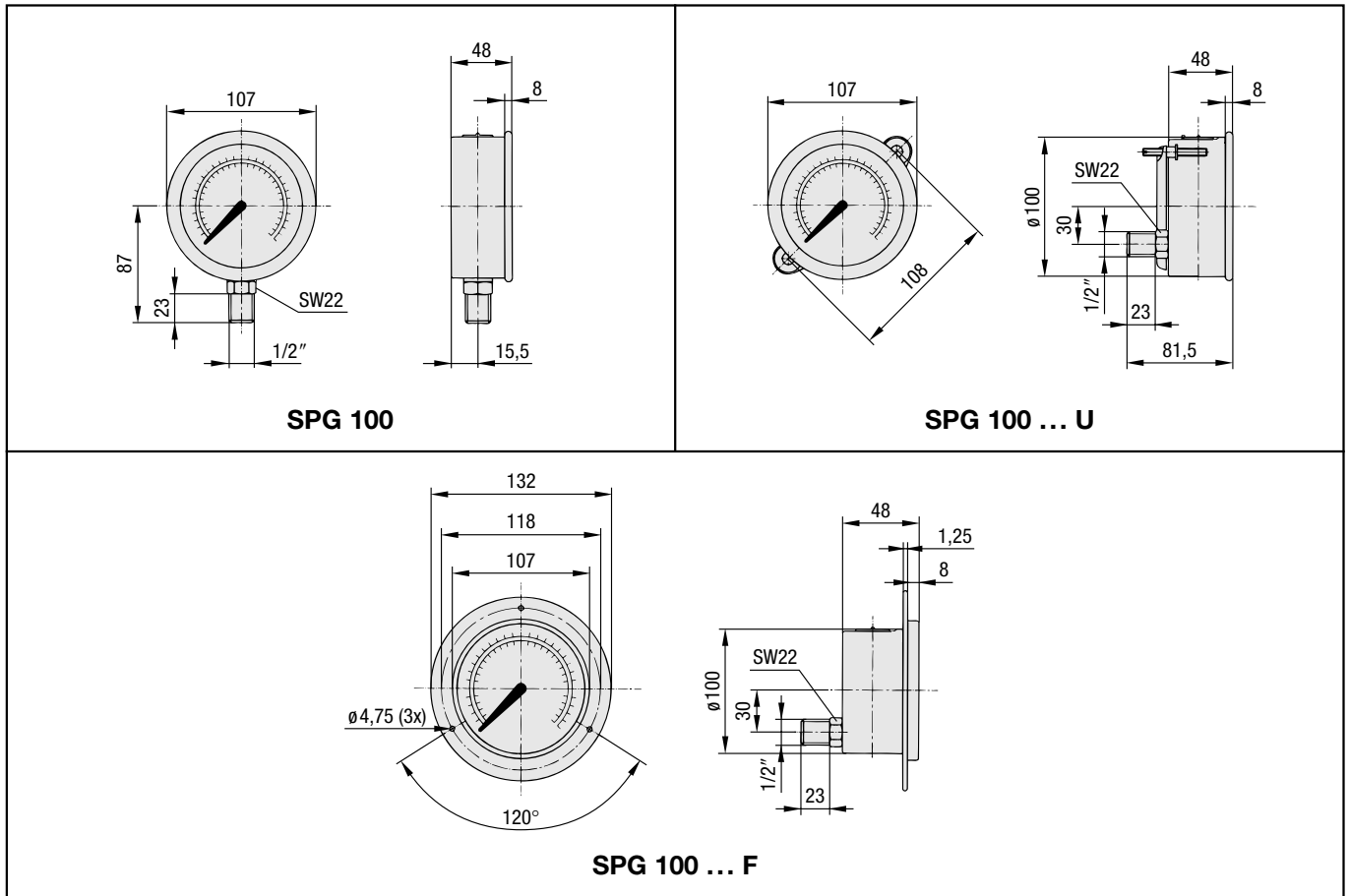

Ordering Code

SPG 063 - 0-160 - 1 - R - B - U

Type		Accessories (for rear entry only)	
SPG	Stainless steel pressure gauge	(none)	no accessory
Size		U	U-bolt assembly
063	63 mm with G ^{1/4} or 1/4 NPT connection	F	Front flange assembly
100	100 mm with G ^{1/2} or 1/2 NPT connection	Thread size	
Pressure range		B	BSP (G ^{1/4} or G ^{1/2}) (standard)
-1 - 1,5	(-1) - 1,5 bar / 21 PSI	N	NPT (1/4 NPT or 1/2 NPT) (only on request)
-1 - 3	(-1) - 3 bar / 42 PSI	Adaption	
0 - 10	0 - 10 bar / 145 PSI	S	Stem mounting
0 - 16	0 - 16 bar / 230 PSI	R	Rear mounting
0 - 25	0 - 25 bar / 360 PSI	Style of scales	
0 - 40	0 - 40 bar / 580 PSI	1	BAR/PSI (bar outside / PSI inside)
0 - 60	0 - 60 bar / 850 PSI		
0 - 100	0 - 100 bar / 1.450 PSI		
0 - 160	0 - 160 bar / 2.300 PSI		
0 - 250	0 - 250 bar / 3.600 PSI		
0 - 400	0 - 400 bar / 5.800 PSI		
0 - 600	0 - 600 bar / 8.500 PSI		
0 - 680	0 - 680 bar / 10.000 PSI		
0 - 700	0 - 700 bar / 10.000 PSI		
0 - 1000	0 - 1000 bar / 14.500 PSI		



Area of Application:

protection against pressure gauge overload (single station) or 6 position pressure measurement (multi-station)

Characteristics:

- suitable for hydraulic fluids
- max operating pressure: 350 bar
- connection thread size: G 1/4; 1/4 NPT for single station valves on request
- temperature range: 100°C max
- complete with operation manual (plate mounted to the product)

Please consult our office before you use SWS with other fluids.

Dimensions SWS-B04-S1

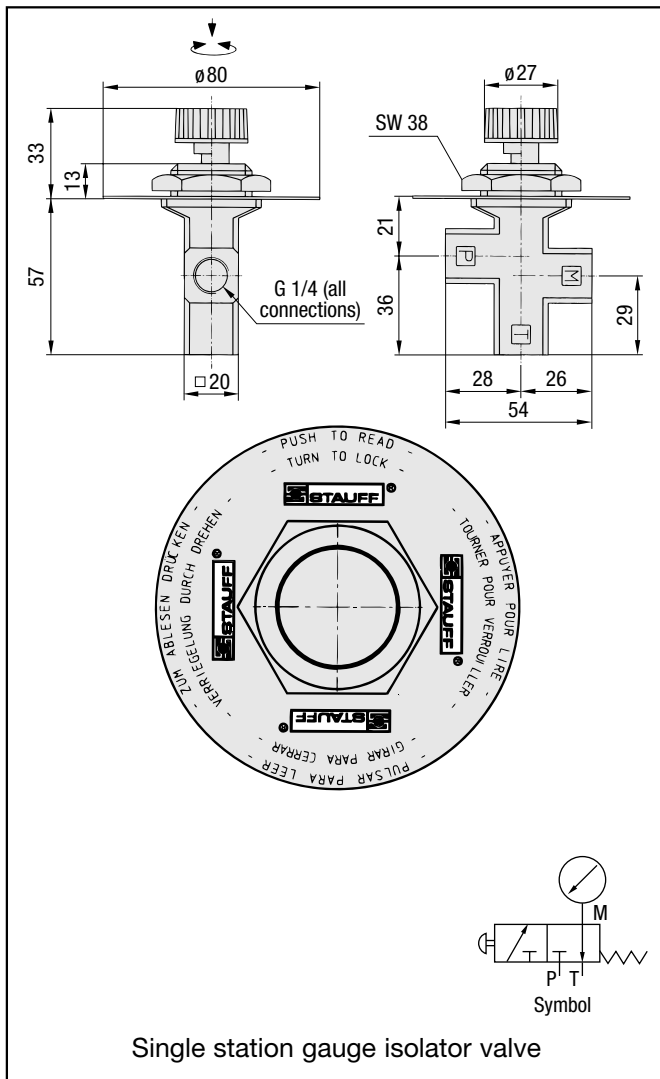

Dimensions SWS-B04-M

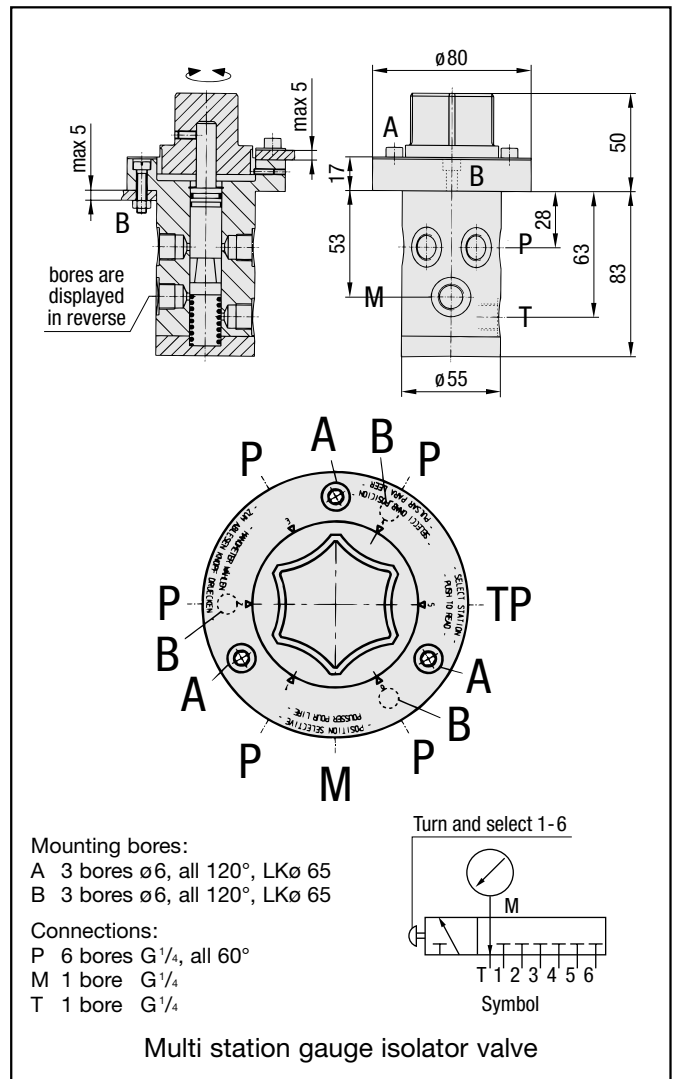

Ordering Code

